

 **BEST
PLUMBER**

604 
RACING SERIES

 **PRESENTED BY**

 **LONGHORN**
CHASSIS

General Rules:

- 1.) The Rules and/or Regulations set forth herein do not express or imply warranty of safety from publication of or compliance with Rules and/or Regulations. These rules are intended as a guideline for the conduct of the **Best Plumber 604 Crate Late Model Racing Series** events, and are in no way a guarantee against injury or death to participants, spectators, or officials.
2.)The Rules and/or Regulations will apply to all **Best Plumber 604 Crate Late Model Racing Series** events.
3. **Host Track officials** shall have full authority over said events, and in the event of any dispute, the head track official's decision will be final.
4. All competitors and cars are subject to inspection by **Host Track** Technical Inspectors or their representatives at any time during any event.
5. **Host Track** and it's officials and representatives reserve the right to confiscate any suspicious or deemed illegal parts or components.
6. **Best Plumber 604 Crate Late Model Racing Series** reserves the right to alter or amend these Rules and/or Regulations in the interest of fair competition, efficient completion of an event, or for safety. All official's decisions are final.
- 7 . There is NO appeal process in the determination of or application of fines and/or penalties assessed by the series. All **Host Track** official's decisions are final, and drivers will not be allowed to compete in any events until all fines are paid, penalties assessed have been cleared, and/or suspensions have been served.

Event Structure

1. The **Best Plumber 604 Crate Late Model Racing Series** will be run under the following format:
 - a. **Hot Laps**
 - i. **2 laps / 5 cars at a time**
 - b. **Qualify (if more than 28 cars registered qualifying will be divided into two groups)**
 - i. **GWC / 2 cars at a time**
 - c. **Heat Races**
 - i. **No more than 8 cars in heat**
 1. **For avoidance of doubt:**
 - a. **if 16 cars then there will be 8 cars in 2 heat races**
 - b. **if there are 17-23 cars there will be 3 heats, 2 of which will have 6 cars and one heat with 7 cars**
 - c. **if there are 24 or more cars there will be 4 heat races**
 - d. **Leader starts all heat races**
 - d. **A-Main**
 - i. **The top 20 qualifying drivers will make it into the A-Main**
 1. **For avoidance of doubt:**
 - a. **If 20 cars or less qualify they will all run in the 20 lap A-Main feature.**
 - b. **The feature will be 30 laps**
 - e. **B-Main**
 - i. **If 29 or more cars, then cars not transferring through heat will go to a B main at which top 4 will transfer to the feature.**
 - f. **Provisional**
 - i. **Top points driver that does not qualify for the feature after heat races will be eligible for a points provisional. Driver must have attempted to start hot lap.**
 - ii. **Driver will be able to start 21st in the feature**
 - iii. **21st position will not pay.**

Points per race	
1.	100
2.	96
3.	94
4.	92
5.	90
6.	88
7.	86
8.	84
9.	82
10.	80
11.	78
12.	76
13.	74
14.	72
15.	70
16.	68
17.	66
18.	64
19.	62
20.	60

Payouts per race

1st \$3,000

2nd \$1,500

3rd \$900

4th \$700

5th \$600

6th \$550

7th \$500

8th \$450

9th \$400

10th \$350

11-20th \$300

Total Payout per race = \$11,950

Championship Payouts

1st \$15,000 and \$10,000 credit towards a roller or a powder coated chassis from Longhorn

2nd \$8,000 and a custom seat from Victory seats

3rd \$5,000

4th \$1,500

5th \$1,000

6th \$ 600

7th \$ 500

8th \$ 500

9th \$ 500

10th \$ 500

Total Payout = \$32,200

Notes regarding points and payouts:

1. Each driver will be allowed to drop 1 race. It can be a missed race or worst finish.
2. If a driver misses 3 or races over the series the driver will only be eligible for 50% of any championship points money earned.
3. Each driver will receive 40 points for the event if they enter the event and attempt a hot lap.
4. In the event of an owner / ride change the championship points money will payout by the exact percentage of the W9 on file for the season.
 - a. i.e.
 - i. If driver has same W9 for 100% of the season 100% of the money will pay to that W9
 - ii. If driver has a W9 for 50% of the races in season and a different W9 for other 50% the points money will pay 50% to one and 50% to the other.

Rainouts:

1. If there are rainouts the organizers will make good faith effort to accommodate participants in the scheduling of make-up races but there will be no special considerations made for any driver or owner or track.

Safety Rules:

1. Safety is the primary responsibility of the RACER!!
2. SFI-Approved full fire suit (top and bottom) and shoes required. Gloves not required, but highly recommended.
3. Snell rated SA2015 or SA2020 full-face helmet required.
4. All current seats must be full containment type constructed of aluminum or approved carbon fiber and must adhere to the general design specifications of SFI 39.2 seat construction standards. Design should include comprehensive head surround, shoulder and torso support system, energy impact foam, and removable head foam.
5. Series recommends the use of a head and neck restraint system, but is not required.
6. All cars must have a fully charged 2 lb. fire extinguisher mounted within reach of the driver. Series recommends a 5 lb. halon system.
7. All cars must have a kill switch within easy reach of the driver, and clearly marked "Off" and "On".
8. All cars must have a quality fuel cell with roll over valve(check valve) in fuel cell vent.
9. Minimum three(3) inch wide, or two(2) inch if using head and neck restraint, SFI-Approved five point safety belts, mounted securely to the roll cage. Belts cannot be used past their expiration date or two(2) years past their date of manufacture.
10. Any pre-race technical/safety inspection and car or equipment is deemed unsafe by officials will result in not being allowed to compete. Official's decisions are final!
11. All track specific general safety rules or requirements will apply at all times to all participants(i.e. window nets, gloves, door plates, head and neck restraints, etc.) at that track.
12. RaceCeiver one way radios are REQUIRED at every event. Failure to have a RaceCeiver(or equivalent one-way device) could result in disqualification. Malfunction of such device (i.e. dead battery, ear phone failure, etc.) will not constitute any penalty.
13. NO two-way radios, cell phones, or other communication devices will be allowed. RaceCeiver is the ONLY communication device permitted. Drivers caught with any other communication device will be disqualified for that event (heat or feature).No lit signal devices allowed (light sticks, flashlights, cell phones, etc.)
14. No mirrors are allowed at any location on the car.
15. ALL weight/lead must be painted white and include the car number. Weight must be securely fastened to the car with a minimum two (2) ½" diameter bolts. No weight may be attached to the back bumper. Losing weight in any race (i.e. heat, b-main, feature) will result in disqualification for that event.
16. In the event a racetrack has additional safety rules not required by the series then the safety rules for the host racetrack supersede the safety rules of the series.

Track Race Procedures:

1. In the event of rain at **Host Track** during a scheduled event, and the feature event has not completed more than half (1/2) the advertised laps, that event must be either canceled completely or rescheduled at the series discretion.
2. **Host Track** officials are required to enforce the technical and procedure rules and regulations of the series as fairly and completely as possible.

Technical Rules and Regulations:

1. The **Best Plumber 604 Crate Late Model Racing Series** will be governed by the technical rules and regulations as described in the Crate Racin USA Weekly Late Model Rules **with the exception of tires, weight, deck height (in place of droop rule), engine protest rules and seals.**
 - a. <https://weeklylatemodels.crateracinusa.com/downloads/get.aspx?i=1173817>
 - b. For avoidance of doubt note that rear quarter spread at bottom is not allowed to be more than 86"
 - c. All cars must have a working starter when being P&G tested.
 - i. Top 3 cars will be P&G tested
 - ii. Top 5 cars will be held until the top 3 have passed inspection
 - d. Deck height will be 39" max
 - e. Protest
 - i. Best Plumber 604 Racing series will abide by the published protest rules as outlined in the American All Star Racing series rules for 2026
 1. The protesting party may bypass the dyno and move straight to a tear down for a fixed cost of \$3,000.
 - ii. The series reserves the right to dyno or tear down the motor of any driver that participates in any of our events at series expense.
 - f. Seals:
 - i. All engine seals that are approved for both the the Crate Racin USA series and American All Star series are allowed to run in the Best Plumber 604 Racing Series.
 - g. STAKT
 - i. Stakt doors and quarter panels are allowed in the Best Plumber 604 Racing Series.
 - h. Fuel Samples
 - i. From time to time series officials will elect to perform a fuel sample. If there are any doubts regarding the result the series official may elect to allow the driver to participate and send the sample to the lab. Drivers pay will be held until results are final.

Tire Rules:

- 1.** Tires: Front Open
- 2.** Left Rear Hoosier Crate 21 or American Racer Pro 2
- 3.** Right Rear: Hoosier Crate 55 or American Racer Pro 4
- 4.** All Hoosier Tires must be shoulder-plated.
- 5.** Sipping and Grooving Allowed.
- 6.** No Grinding of numbers or compound, Any Tire that has been altered will be illegal and confiscated. Tires can be checked with a durometer, no chemical treating of tires allowed. All tires subject to sampling at any time. Failure to comply with this warning could result in premature or catastrophic tire failure and may result in serious injury or death.
- 7.** Drivers finishing in the top 5 may protest the tire of car or cars finishing ahead of them. Protest fee is \$125.
- 8.** Driver filing protest must have money with them and notify track or series official within ten (10) minutes of the checkered flag in that event. Tire samples will be taken and sent to an independent lab chosen by the series for testing. All official's decisions and lab results are final and official.
- 9.** Penalties for illegal tires:
 - a.** First Offense - \$300 fine and 30-day suspension
 - b.** Second Offense - \$500 fine and 90-day suspension
 - c.** Third Offense - \$1,000 fine and 365-day suspension
 - d.** Failure to allow any tire(s) to be confiscated will result in an additional \$500 per tire fine added to any other fines and penalties. All decisions are final.

Weigh-In Rules:

- The weight requirement is 2300 pounds at any time
- **ALL TRACK AND SERIES OFFICIAL'S DECISIONS ARE FINAL.**

Event Fines, Penalties, and Suspensions:

- As determined by **Host Track** officials
- No hitting under caution. Hitting under caution will result in immediate disqualification.
- **ALL TRACK AND SERIES OFFICIAL'S DECISIONS ARE FINAL.**

Code of Conduct and Conduct Penalties:

- As determined by **Host Track** officials
- **ALL TRACK AND SERIES OFFICIAL'S DECISIONS ARE FINAL.**

ATTENTION CAR OWNERS AND DRIVERS:

- Please remember that we are here and can race because of the fans, promoters, and sponsors. If they don't benefit, we won't benefit. While we understand that this competition involves substantial financial stakes, there is no excuse for bad or unruly behavior which would tend to bring the series, tracks, or sponsors into disrepute.
- PLEASE NOTE: By entering, qualifying, and/or competing in a **Best Plumber 604 Crate Late Model Racing Series** event, you are accepting these rules and regulations as being those under which you are prepared to race. Any driver entering and competing in a **Best Plumber 604 Crate Late Model Racing Series** event acknowledges and accepts the following: **Best Plumber 604 Crate Late Model Racing Series Series** and its assigns may use the drivers names, pictures, likeness, and performance in any way, medium, or material, including without limitation by and through, television, radio, air wave: cable and satellite broadcasts, film productions, videotape reproductions, audiotape reproductions, transmissions over the internet, and public and private on-line services authorized by the **Best Plumber 604 Crate Late Model Racing Series series** and the like, before, during, and after the event, for promoting, advertising, recording or reporting in the event or any other **Best Plumber 604 Crate Late Model Racing Series Series** event, and do hereby relinquish all rights there to for these purposes, provided however, that the car owner and driver shall retain the exclusive use of its or his/her name, picture and likeness in connection with product endorsements or any other use at the sole discretion the series directors.

ENTRY FEE:

- Please note – Each host track will charge a \$100 entry fee per car.
- Please note- the series champion from the prior years series is not required to pay an entry fee.

Media Production Agreement:

- By participating in any sanctioned events the driver and all crew and affiliates of the driver are acknowledging that the series stakeholders are producing media in many different forms for the series. All drivers participating agree to participate in pre and post race interviews if requested and within reason to allow the media crew access in and around their racing operations while at the track. All drivers in the top 10 of the points coming into and leaving the event and all drivers finishing in the top 5 of the event will be obligated to speak to the media before leaving if asked.

Rookie of Year

- Must apply to run for rookie of the year prior to first event. Series organizers will review applicants and notify you if eligible to run for rookie of the year.
- Rookie of the year prize will be awarded to the approved ROY participant that scores the most points throughout the year.
- Prize for ROY is
 - 1st \$1,500
 - 2nd \$1,000
 - 3rd \$500

Series decals

- The series organizers will provide decal stickers that must be run on both sides of the car in each of our races. If any participant does not run decal on both sides of the car then they will be penalized.
 - 1st offense - Warning
 - 2nd offense - Half points
 - 3rd offense - No points
 - 4th offense - Half money for event and no points

Note – in a non-points event if the car does not run the sticker they will be docked half of pay for their finishing position.

Body Rules Reference:

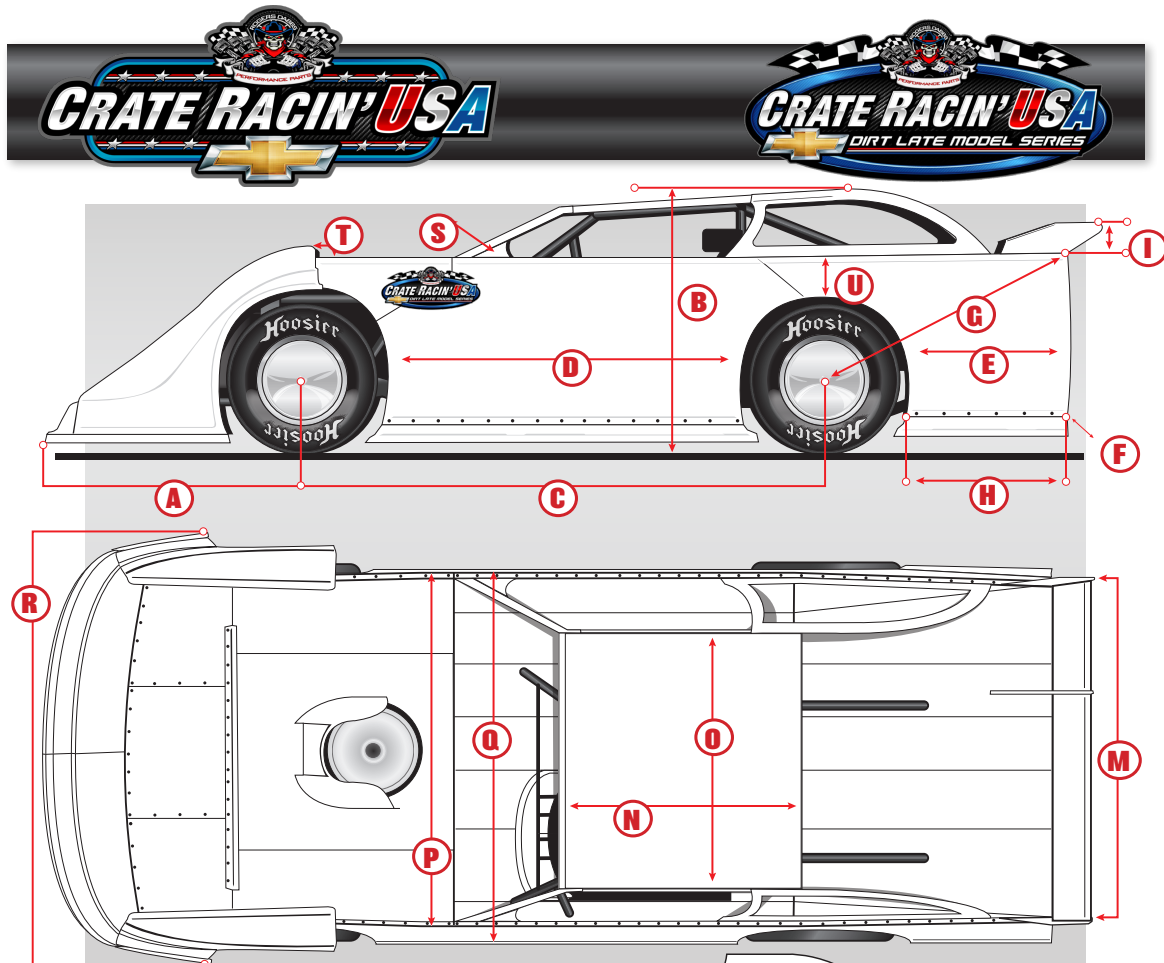

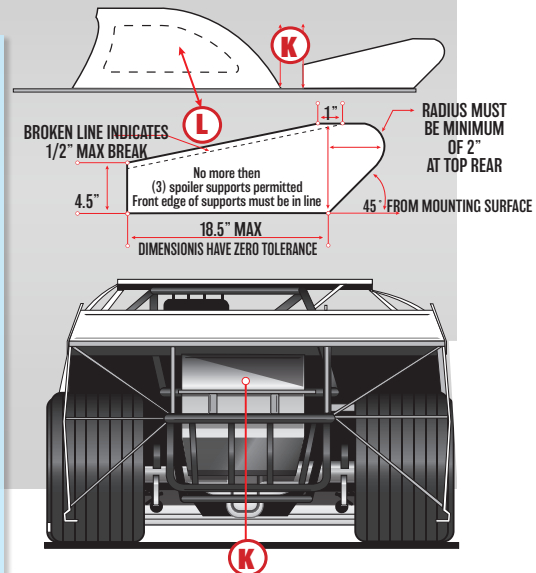

2026 LATE MODEL DIMENSIONS

- A)** Stock Nosepiece can extend maximum of fifty-two inches (52") from center of front hub to farthest point extending forward.
- B)** Roof height must be minimum of forty-five inches (45") and maximum fifty-two inches (52") max from the ground.
- C)** Wheelbase must be one-hundred, 3 inches (103") minimum.
- D)** Doors and quarters must be flat or may have an outward roll. No doors or body panels allowed to be rolled inward.
- E)** No dishing allowed on rear quarter panels. Must remain flat.
- F)** Skirting material must be cut off flush with rear quarter panel.
- G)** Fifty-four inches (54") maximum from center of rear hub to top of quarter panel.
- H)** Forty-nine inches (49") maximum from center of rear hub to end of quarter panel.
- I)** Eight inches (8") spoiler height maximum.
- J)** No wings or "tunnels" of any kind allowed underneath the body or chassis.
- K)** Minimum two-inches (2") space between rear spoiler and rear sail panel.
- L)** Rear sail panels must match. Can be open or closed, but both must be the same.
- M)** Seventy-two inches (72") spoiler width maximum.
- N)** Roof length must be minimum of forty-four inches (44") to maximum of fifty-four inches (54").
- O)** Roof width must be minimum of forty-eight inches (48") to maximum of fifty-two inches (52").
- P)** Maximum of seventy-eight inches (78") wide at top of doors.
- Q)** Maximum of eighty-six inches (90") wide at bottom of doors.
- R)** Maximum of ninety-two inches (92") wide at front/widest part of car.
- S)** Window supports maximum of seven inches (7") in length in each direction, up or back.
- T)** Front fender flares may not be more than four inches (4") higher than fenders.
- U)** 1. Left rear wheel opening between the quarter panel and the door must be a minimum of twenty-eight inches (28") with a maximum of thirty-three inches (33"). 2. Right rear wheel opening between the quarter panel and the door must be a minimum of twenty-nine inches (29") with a maximum of thirty-two inches (32") and a Maximum of nine inches (9") from the top of the quarter panel to the wheel opening above the hub.



Schedule Reference

01		APRIL 18 Wartburg	07		AUGUST 8 Wartburg
02		APRIL 25 Smoky Mountain	08		AUGUST 15 Smoky Mountain
03		MAY 9 I - 75	09		AUGUST 29 Volunteer Speedway
04		MAY 24 Tazwell	10		SEPTEMBER 5 I - 75
05		JUNE 6 Volunteer Speedway	11		SEPTEMBER 19 Tazwell
06		JULY 4 Thunder Mountain	12		OCTOBER 17 Thunder Mountain

PreRace Tech Check Reference

- Car #
- Driver Name
- Engine Builder
- Seals
 - Who issued and are they current and up to date?
- Deck Height
 - 39"
- 92" max width at front of car
- 72" spoiler width max
- Rear sail panel match
- Fin must not extend past seat
- 86" max width at back of car

Contact info:

Please contact the series on our official Best Plumber Racing Series FB page or call **Nick Perry** at **865.776.4952**